



<b>AEROSPACE INFORMATION REPORT</b>	<b>AIR5388™</b>	
	Issued 2001-06 Reaffirmed 2022-09	
Unique Wheel and Brake Designs		

## RATIONALE

AIR5388 has been reaffirmed to comply with the SAE Five-Year Review policy.

## INTRODUCTION

Wheels and brakes in current use are generally very similar in design configuration. This has resulted from the sum of experience gained through the years as various designs were tried to meet unique requirements. Typical of modern brakes are the steel and carbon heatsink brakes shown in Figures 1 and 2. They consist of a forged aluminum piston housing, forged steel torque tube and a heat sink consisting of a pressure plate, alternating rotors and stators and a backing plate. Mechanical adjusters are used, generally of an extruding tube design. On carbon-carbon composite heat sink brakes, the adjusters are integral with the piston assemblies. On steel brakes, they are generally separate units. For bogie gears, the brake is bearing mounted on the axle, with one bearing being integral with the piston housing and the second at the mid-length of the torque tube. On two-wheel twin gears, the brake may be either bearing mounted or flange mounted.

Figure 3 shows a typical wheel design. Wheels are typically forged aluminum with an “A” cross-section. To accommodate the large brakes required, the web is normally offset significantly to the outboard side. Fuse plugs and over pressurization protection devices are included.

This Aerospace Information Report describes wheel and brake designs that are not typical, resulting from unique requirements and in some cases working very successfully.

SAE Executive Standards Committee Rules provide that: "This report is published by SAE to advance the state of technical and engineering sciences. The use of this report is entirely voluntary, and its applicability and suitability for any particular use, including any patent infringement arising therefrom, is the sole responsibility of the user."

SAE reviews each technical report at least every five years at which time it may be revised, reaffirmed, stabilized, or cancelled. SAE invites your written comments and suggestions.

Copyright © 2022 SAE International

All rights reserved. No part of this publication may be reproduced, stored in a retrieval system or transmitted, in any form or by any means, electronic, mechanical, photocopying, recording, or otherwise, without the prior written permission of SAE.

**TO PLACE A DOCUMENT ORDER:** Tel: 877-606-7323 (inside USA and Canada)  
Tel: +1 724-776-4970 (outside USA)  
Fax: 724-776-0790  
Email: CustomerService@sae.org  
**SAE WEB ADDRESS:** http://www.sae.org

**For more information on this standard, visit**  
<https://www.sae.org/standards/content/AIR5388/>

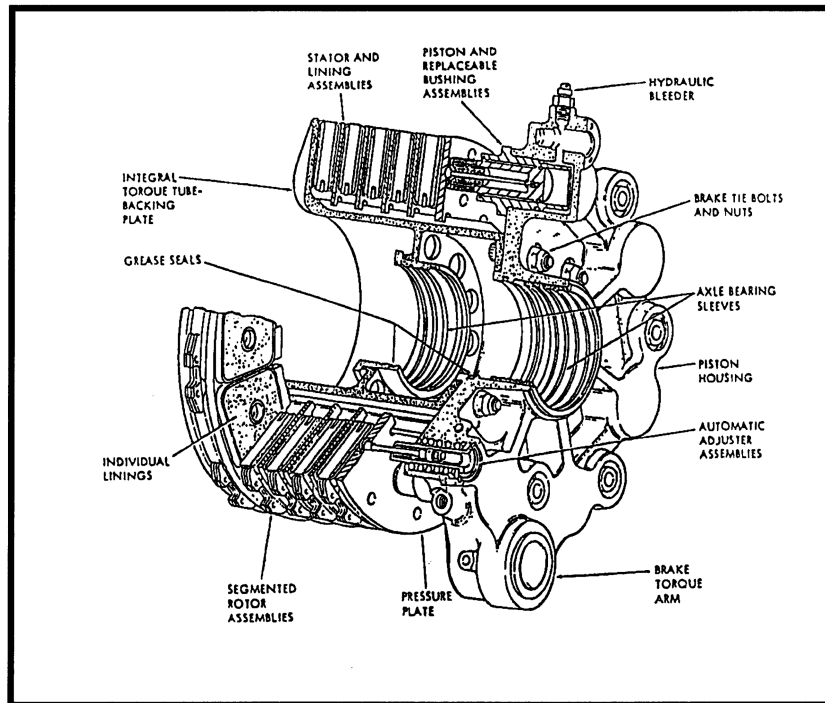

FIGURE 1 - Typical Steel Heat Sink Brake

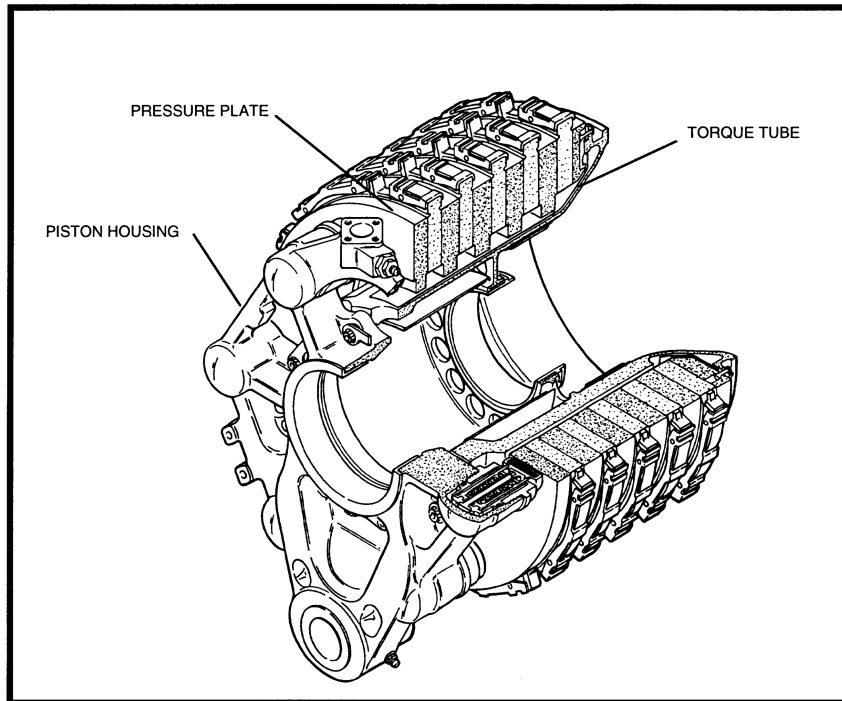

FIGURE 2 - Typical Carbon Heat Sink Brake